

DWG NO
289W1

SEE # 310W2 (S10X)

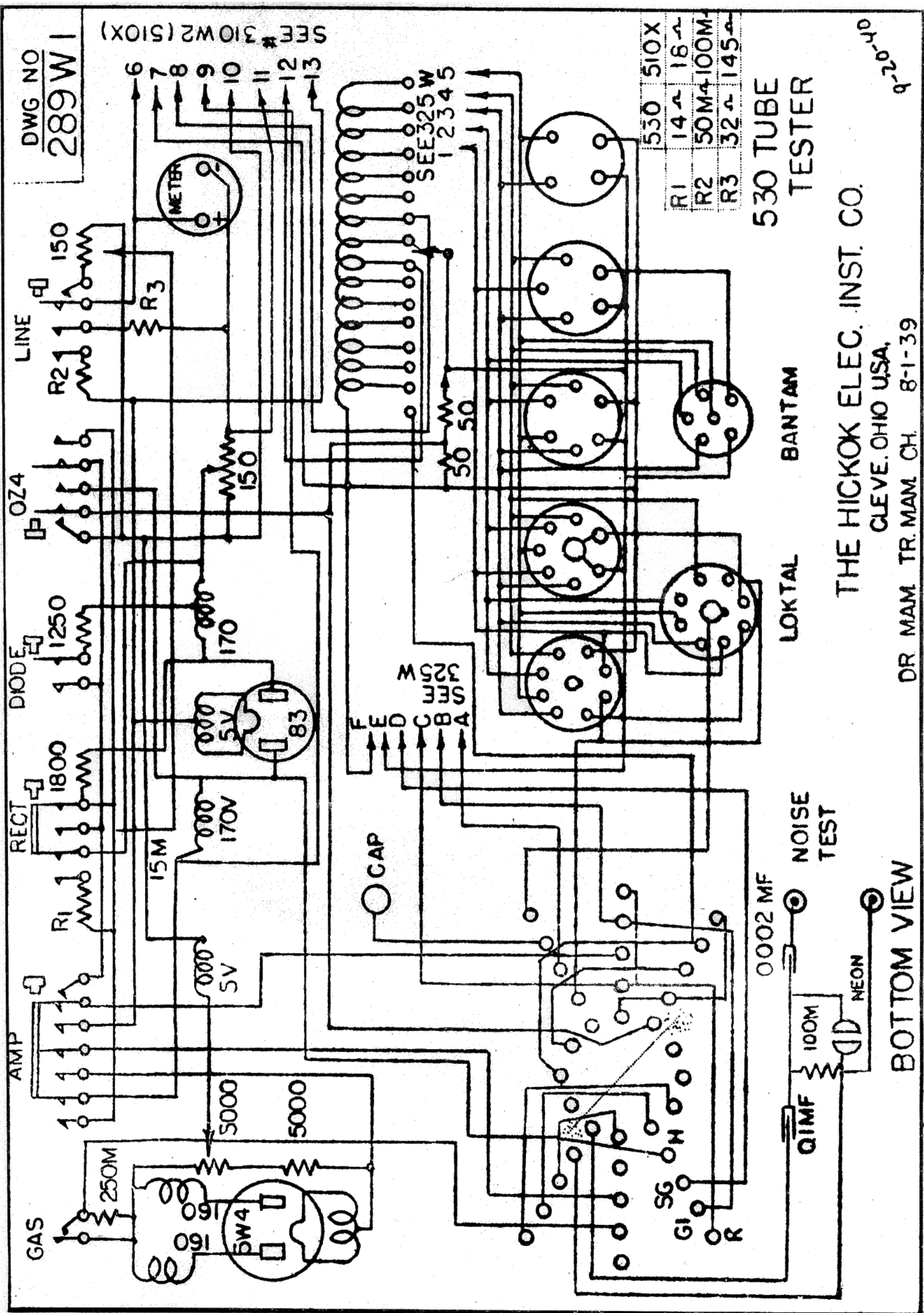

R1	14	18
R2	50M	100M
R3	32	145

530 TUBE
TESTER

LOKTAL BANTAM

THE HICKOK ELEC. INST. CO.
CLEVE. OHIO USA,

DR MAM TR. MAM CH. 8-1-39

9-20-40

0002 MF NOISE TEST

Q1MF 100M NEON

BOTTOM VIEW

DRAWING NO.

325-W

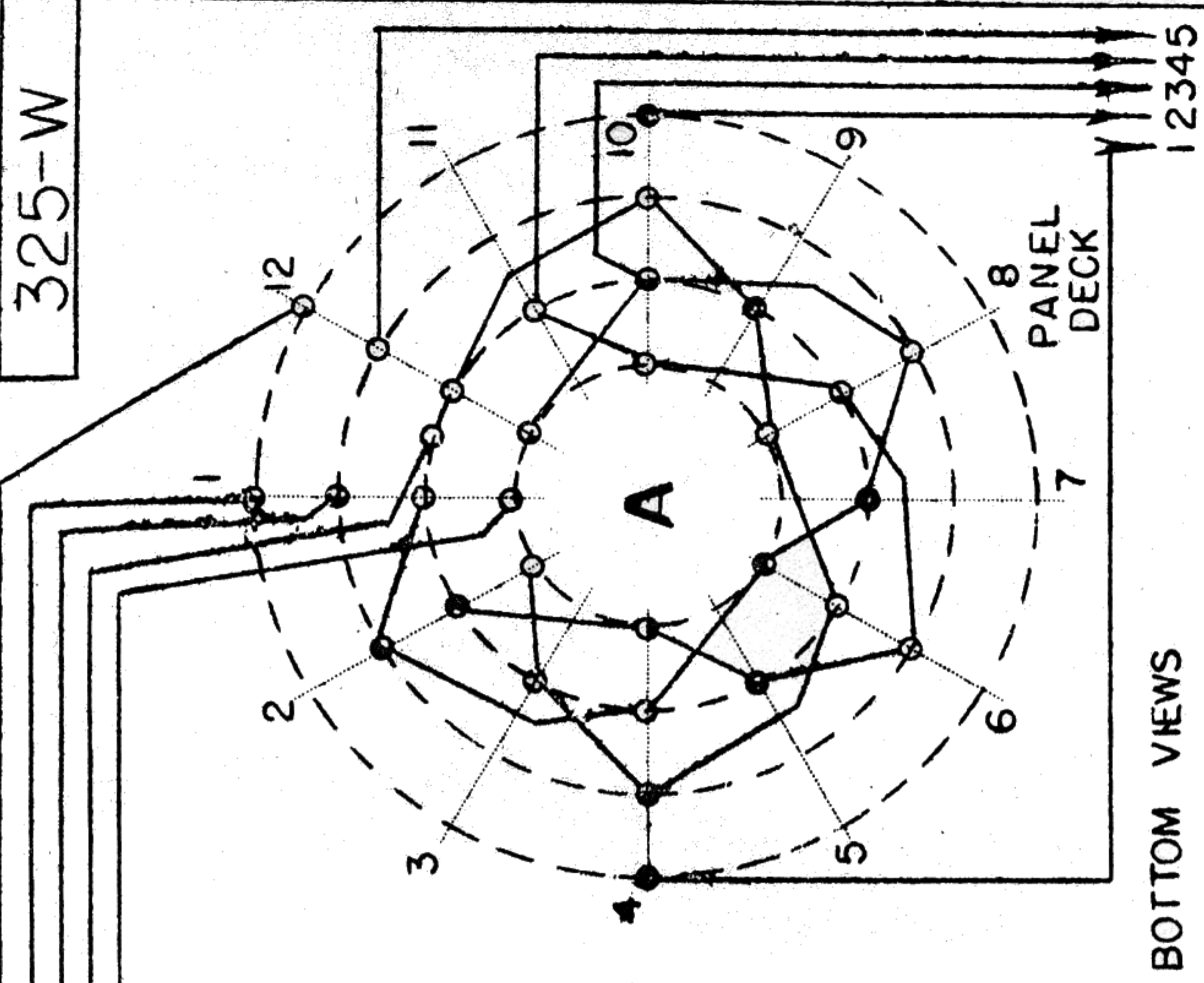

BOTTOM VIEWS

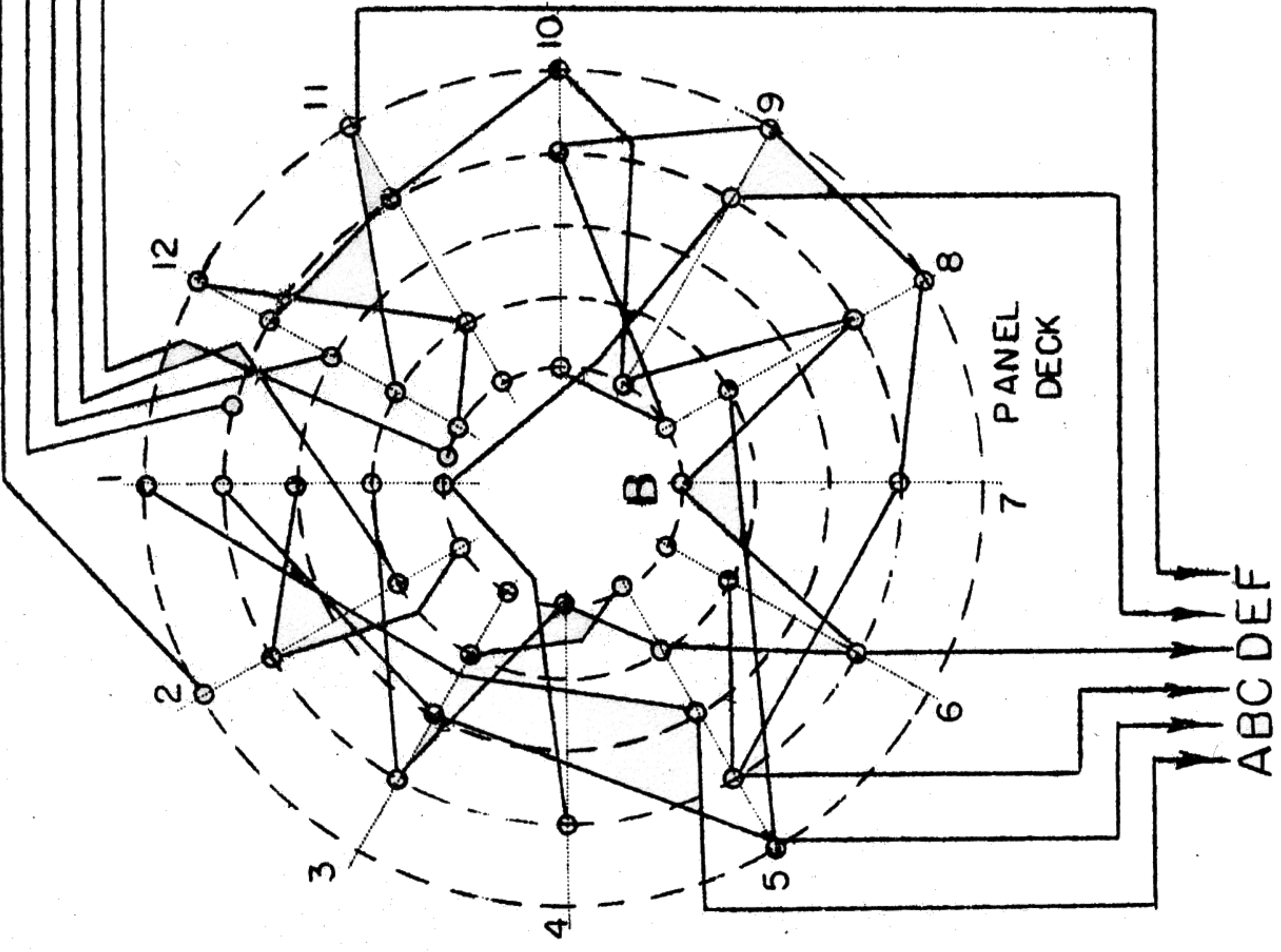

WIRING DIAGRAM

PERM SWITCHES	530 & 510 X			
DRAWN	TRACED	CHECKED	APP'D	DATE
<i>WVX</i>	<i>WVX</i>	<i>F.R.</i>		10-10-38

THE HICKOK ELECTRICAL INSTRUMENT CO.
CLEVELAND, OHIO

DWG NO
310W2

SEE WIRING DIA 289 W1

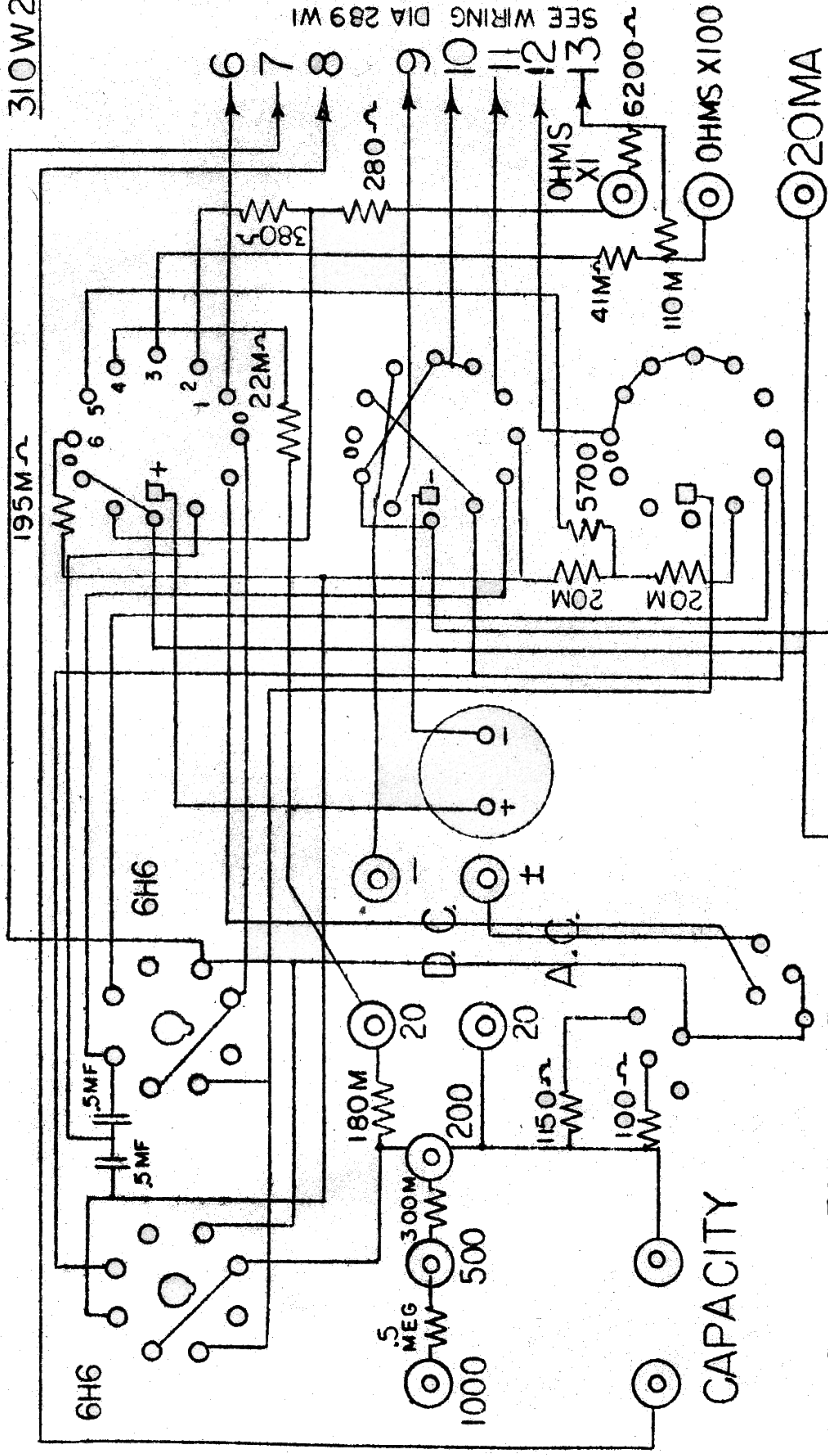

31.4~ 31.4~
200 - 0
MA. OHMS

BOTTOM VIEW

THE HICKOK ELECTRICAL INST. CO.

CLEVE. OHIO U.S.A.

DR. TR. CH. DATE
8-1-39

510X SETTESTER PORTION

This Document Provided Free

At

www.StevenJohnson.com

NOT FOR RESALE