

July 3, 1928.

1,675,401

W. ALFERINK
COMBINED HOLDER AND AUTOMATIC CIRCUIT BREAKER
FOR ELECTRIC SOLDERING IRONS
Filed Dec. 22, 1926

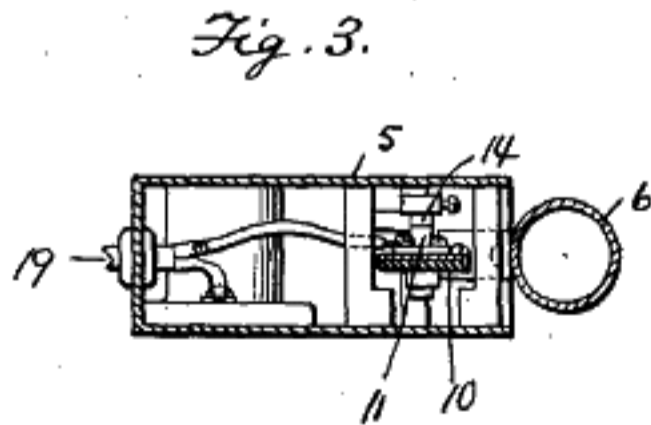
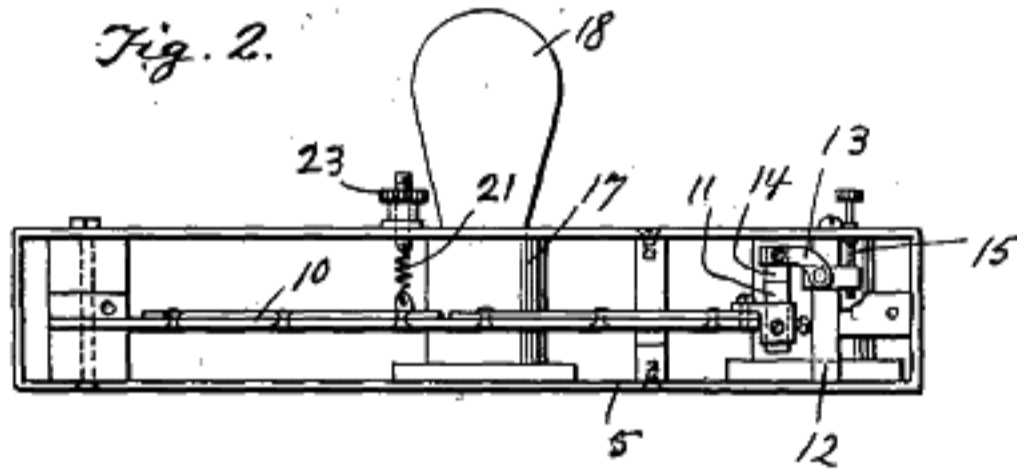
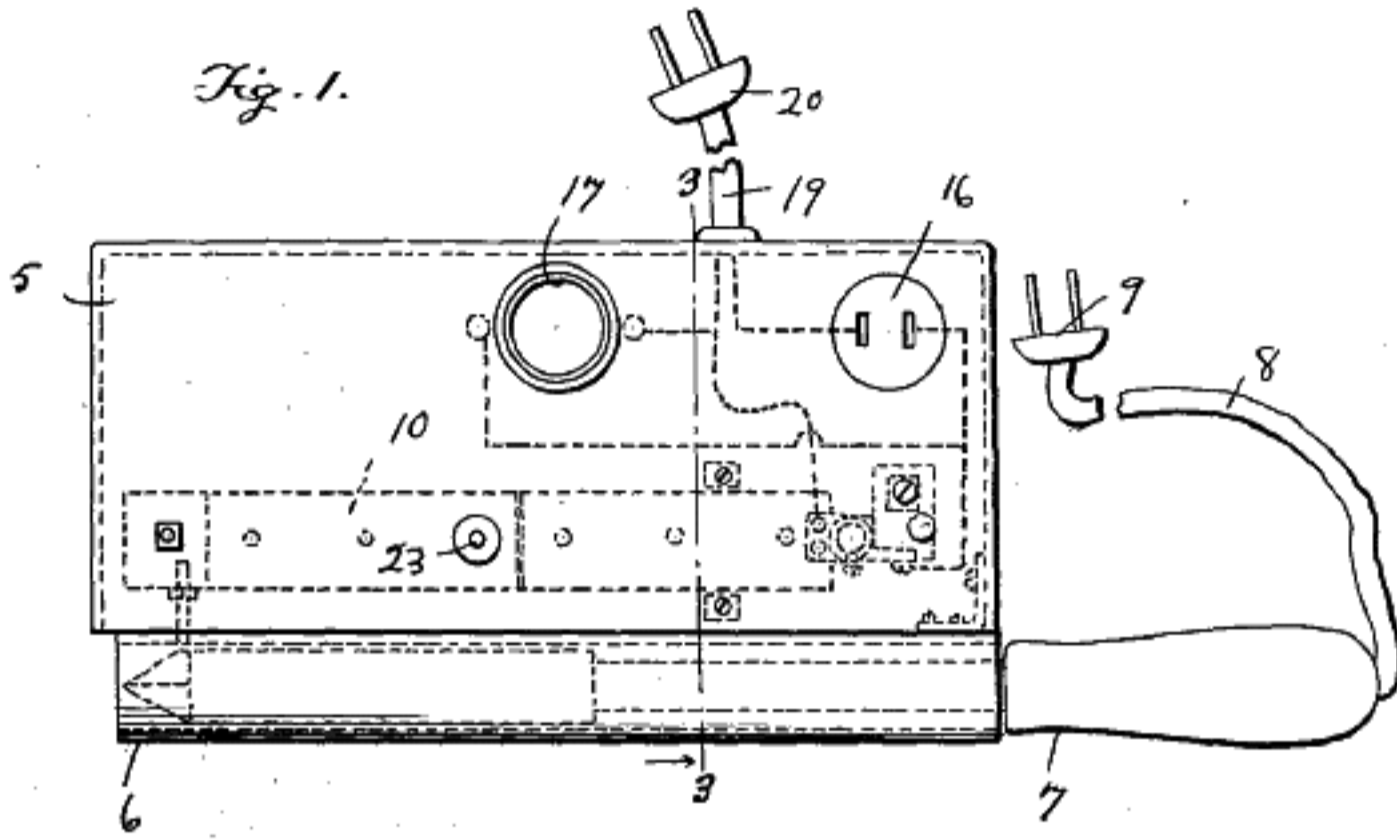

Inventor
William Alferink

By *Clarence A. O'Brien*
Attorney

UNITED STATES PATENT OFFICE.

WILLIAM ALFERINK, OF CLEVELAND, OHIO, ASSIGNOR OF ONE-THIRD TO JOSEPH H. WEAVER AND ONE-THIRD TO CARRIE L. WEAVER, BOTH OF CLEVELAND, OHIO.

COMBINED HOLDER AND AUTOMATIC CIRCUIT BREAKER FOR ELECTRIC SOLDERING IRONS.

Application filed December 22, 1926. Serial No. 156,388.

This invention relates to a combined holder and circuit breaker for electrical soldering irons and has for its primary object to provide a device of this character that is constructed for receiving a soldering iron when the same is not in use, and that has associated therewith a thermostatically controlled switch that may be readily connected to the house electric supply and to which may be electrically connected the soldering iron, with the result that the proper temperature of the iron is at all times maintained, and in order that current will be saved when the iron is properly heated.

A further and important object is to provide a device of this character that is extremely simple of construction, inexpensive of manufacture, and that is otherwise well adapted for all the purposes intended.

Now having particular reference to the drawing,

Figure 1 is a side elevation of my improved device, a conventional soldering iron being disclosed as associated therewith.

Figure 2 is an open edge view of the device, the iron holder per se being removed, and

Figure 3 is a transverse section thereof taken substantially upon the line 3-3 of Figure 1.

Now having particular reference to the drawing, my novel device consists of a relatively rectangular and flat shaped casing preferably of metal and being open at one longitudinal edge as clearly indicated in Figure 2, while at this edge there is secured in any predetermined manner, a relatively elongated metallic tube 6 for receiving the iron portion of a conventional electric soldering iron 7 that is equipped with the electric cable 8 having an attachment plug 9 at the free end thereof.

Arranged longitudinally within the casing 5 adjacent the open edge thereof is a metallic thermostat strip 10 anchored to and insulated from the side walls of the casing as indicated in Figure 2. Upon the free end of this thermostat strip is a contact point 11, while slidable upon a cross pin 12 between the side walls of the casing at the end of the thermostat strip is a contact carrying unit 13 within which is mounted a contact 14. Said unit 13 is adjustably secured to the pin 12 by reason of an elon-

gated threaded screw 15 threaded within the unit and extending through one side wall of the casing as indicated in Figure 2.

The casing 5 is equipped with a complementary socket unit 16 for receiving the plug 9 of the soldering iron cable 8, while said casing is also equipped with a lamp bulb socket 17 within which may be and preferably arranged an electric bulb 18. Leading from the casing is a double wired cable 19 that is equipped with a plug 20 for engagement within an outlet socket of the house current, while one of said wires are electrically connected, as indicated by dotted lines in Figure 1, with one of the contacts of the socket 16, while the other wire thereof is electrically connected to a contact of the socket 17, and to the contact 11 of the thermostat strip 10. The other contact of the socket 16 and the adjustable contact 14 of the thermostat of which are electrically interconnected as indicated by the dotted lines in Figure 1, while this wire also has electrical connection with the other contact of the socket 17 as again indicated by the dotted lines in said figure.

It will be obvious that when the plug 20 is engaged within a socket of the house current and the plug 9 engaged within the socket 16, the circuit will be completed to the soldering iron due to the fact that in a cold state the thermostat 10 is in such position that its contact 11 has engagement with the contact 14. However, when the iron becomes greatly heated, this heat will be imparted to the tube like holder 6, and thence to the thermostat causing the same to expand in such a direction that the contacts 11 and 14 will be separated and the circuit consequently broken, closing the current to the iron, however the light comes on. In other words when the current to the iron is shut off the soldering iron light automatically lights.

In order that the breakage of the circuit may be regulated at different iron temperatures, the thermostat 10 is connected intermediate its ends to one end of a coil spring 21, the other end of which is connected to an adjusting device 23 operable at the outer side of the casing 5 in order that varying tensions may be applied to the spring for adding to the heat resistance of the thermostat.

It will thus be seen that I have provided a highly novel, simple, efficient device for use in the holding of soldering irons and also for use in the automatic making and breaking of the electrical circuit to the irons, that is well adapted for all the purposes heretofore designated and even though I have herein shown and described the invention as consisting of certain detail structural elements, it is nevertheless to be understood that minor changes may be made therein without effecting the spirit and scope of the appended claims.

Having thus described the invention, what I claim as new is:—

1. In a device of the class described, a casing, means associated with the casing for supporting an electric soldering iron, a normally closing thermostatic switch arranged in the casing and operable to open position by a predetermined heat of the iron, said switch comprising a thermostat strip pivoted at one end in the casing, a contact carried by the free end thereof, a pin in the casing, a member slidable and adjustable on said pin, a contact carried by said member, said contacts being in engagement with each other until the iron reaches a predetermined degree of heat whereupon the strip and the contact carried thereby moves away from the second mentioned contact.

2. In a device of the class described, a casing, means associated with the casing for supporting an electric soldering iron, a normally closing thermostatic switch arranged in the casing and operable to open position by a predetermined heat of the iron, said switch comprising a thermostat strip pivoted at one end in the casing, a contact carried by the free end thereof, a pin in the casing, a member slidable and adjustable on said pin, a contact carried by said member, said contacts being in engagement with each other until the iron reaches a predetermined degree of heat whereupon the strip and the contact carried thereby moves away from the second mentioned contact, and means

whereby the switch may be regulated as to operate in a circuit opening manner at predetermined heat degrees of said iron. 50

3. In a device of the class described, a casing, means associated with the casing for supporting an electric soldering iron, a normally closing thermostatic switch arranged in the casing and operable to open position by a predetermined heat of the iron, said switch comprising a thermostat strip pivoted at one end in the casing, a contact carried by the free end thereof, a pin in the casing, a member slidable and adjustable on said pin, a contact carried by said member, said contacts being in engagement with each other until the iron reaches a predetermined degree of heat whereupon the strip and the contact carried thereby moves away from the second mentioned contact, means whereby the switch may be regulated as to operate in a circuit opening manner at predetermined heat degrees of said iron, said last mentioned means comprising a coil spring attached at one end to the intermediate portion of the pivoted strip, and an adjustable device arranged on the outer side of the casing and connected to the other end of the spring for adjusting the tension thereof. 75

4. In a thermostatic switch for irons, a casing, a pin arranged vertically within the casing, a member slidable on said pin, a contact carried by said member, an adjusting screw connected to the movable member and extending through the casing for moving said slidable member to any predetermined adjusted position on the pin, a thermostat strip pivoted at one end in the casing, and a contact carried by the free end of the strip and normally in engagement with the aforementioned contact until the iron reaches a predetermined heat, whereupon the pivoted strip and the contact carried thereby is moved out of engagement with the first mentioned contact. 85

In testimony whereof I affix my signature. 90

WILLIAM ALFERINK.

This Document Provided Free

At

www.StevenJohnson.com

NOT FOR RESALE